

Operating Instructions

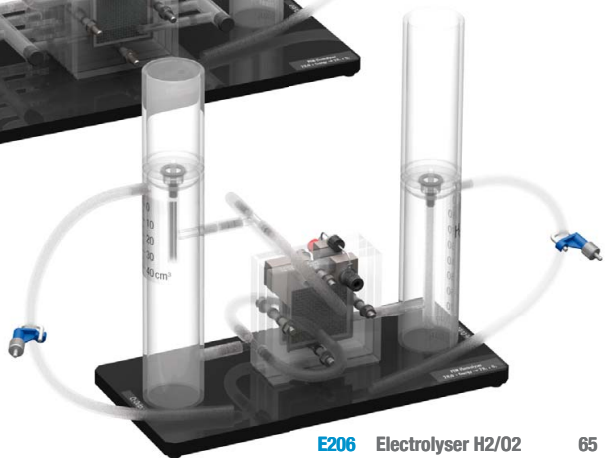

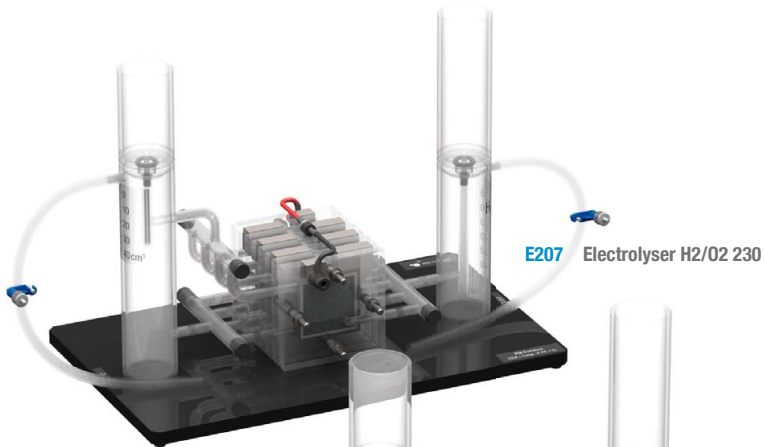

H-TEC EDUCATION
1902 Pinon Dr. Ste. B
College Station, TX 77845
USA

Phone: +1 979-703-1925
Fax: +1 979-343-1122
E-mail: sales@myhtec.com
Website: www.myhtec.com

Table of contents

04	Introduction
05	About these Instructions
05	Safety Instructions
06	Content
08	Overview
10	Starting Up
12	Operation
14	Technical Data
15	Troubleshooting
16	Shutting Down
16	Maintenance
17	Transport and Storage
17	Disposal

Introduction

The significance of PEM electrolyzers is growing alongside the demand for the fuel cell. Electrolyzers use water to produce the hydrogen required by fuel cells in an environmentally friendly manner. The required electricity can be generated as renewable energy, e.g. with solar cells, wind power plants or water power plants.

In the electrolyzer, water uses electricity to react according to the formula $2\text{H}_2\text{O} \rightarrow 2\text{H}_2 + \text{O}_2$. This process takes place in the MEA (membrane electrode assembly). The MEA consists of a cathode, an anode and a special polymer membrane (PEM) which is penetrable to protons but acts as a barrier for electrons. The electrolyzer you purchased from H-TEC EDUCATION works according to the PEM principle. The generated gases can be collected in storage tanks. The energy stored in these in chemical form can be re-converted into electricity using a fuel cell, if and when required.

We hope you enjoy many instructive hours with the PEM electrolyzer.

Sincerely yours,

H-TEC EDUCATION

About these Instructions

These operating instructions are intended for the supervisor in charge.

- These operating instructions must be read and observed before use.
- These operating instructions must be available for reference and must be stored in a safe place.
- All safety instructions must be observed.
- This product may only be put into operation and operated under the direction of the supervisor in charge.

Safety Instructions

Read and observe the general safety instructions included separately with this product and keep them in a safe place together with the operating instructions!

Product-Specific Safety Instructions

The product may only be used:

- According to the intended use
- In compliance with all safety instructions
- In perfect working order

The components of this product feature freely accessible, live electric contact surfaces. Connecting to an impermissible operating voltage can result in a fire hazard, a risk of electric shock and damage to the components.

Product contents

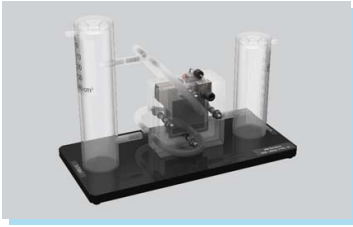

1 x electrolyser (only product E206)

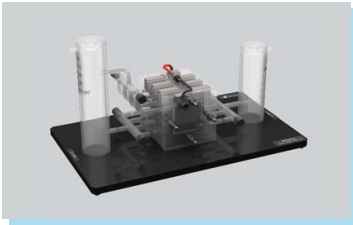

1 x electrolyser (only product E207)

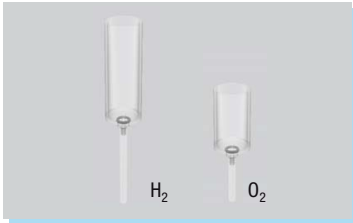

1 x overflow H_2

1 x overflow O_2



1 x water bottle

250 ml with separate tube attachment

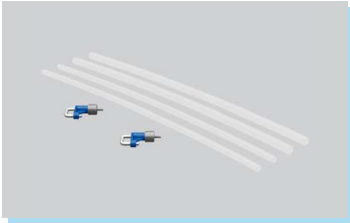

1 x tube set consisting of:
Tubes
2 x tube clamps



1 x operating instructions

Overview

Overview of the "Electrolyser H₂/O₂ 65" (E206) electrolyser

The Electrolyser H₂/O₂ 65 consists of a two-cell electrolysis stack, a hydrogen storage tank and an oxygen storage tank mounted on a baseplate. The two individual cells of the electrolysis stack are electrically connected in series. The center of the electrolysis stack houses the hydrogen side of the two individual cells. The outer sides of the electrolysis stack serve the function of supplying water and removing the oxygen produced. Hydrogen and oxygen are removed via the tubes. The electrolysis stack is equipped with two 4 mm female connectors for connecting multilam plugs. The individual components are shown in the following graphic.

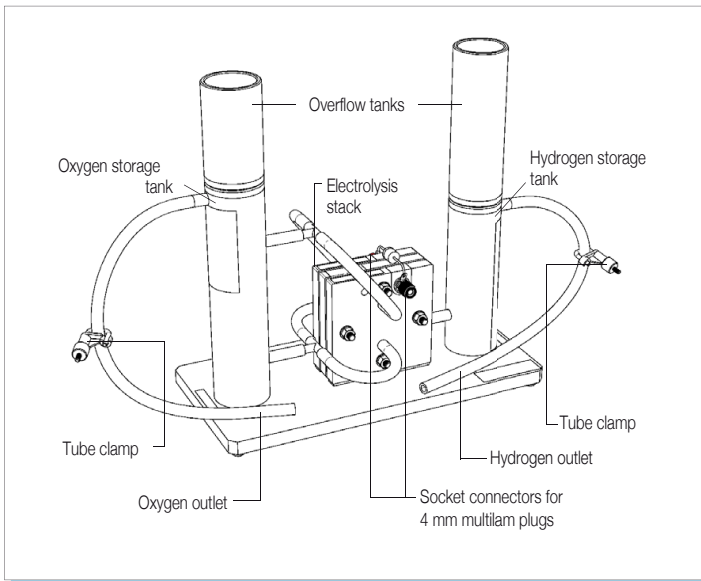

Fig. 1: Overview of E206

Overview of the "Electrolyser H₂/O₂ 230" (E207) electrolyser

The Electrolyser H₂/O₂ 230 consists of a seven-cell electrolysis stack, a hydrogen storage tank and an oxygen storage tank mounted on a baseplate. The seven individual cells of the electrolysis stack are electrically connected in series. Hydrogen and oxygen are removed via the tubes. The electrolysis stack is equipped with two 4 mm female connectors for connecting multilam plugs. The individual components are shown in the following graphic.

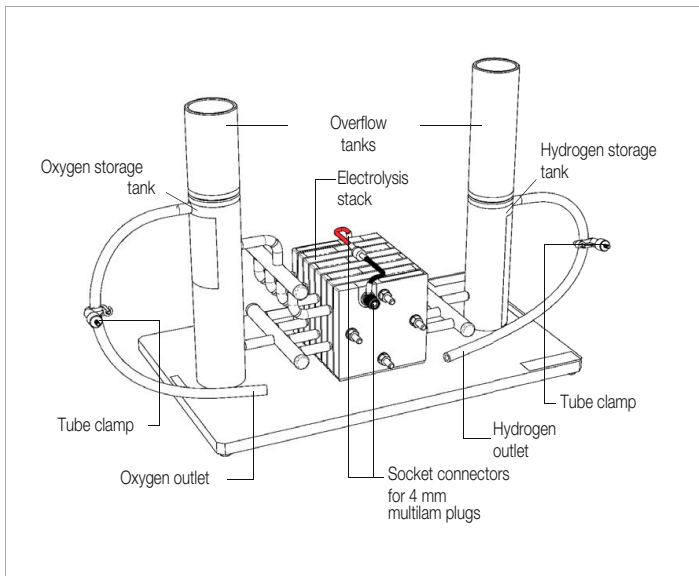

Fig. 2: Overview of E207

Starting Up

Figures 3 and 4 are examples only and applicable to both models. The work steps are identical.

Assembly

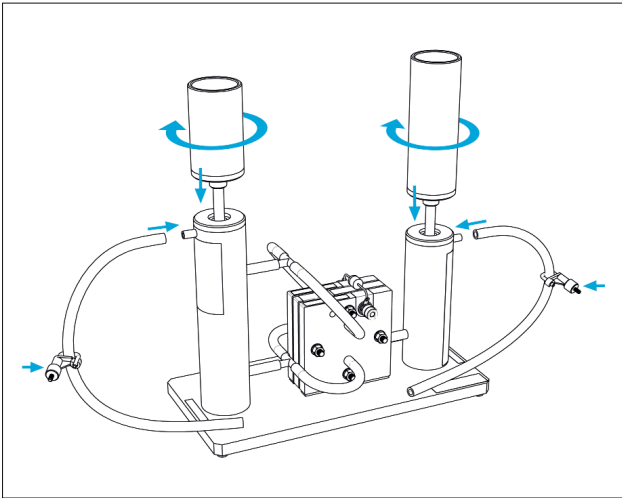

Fig. 3: Assembly
Assemble the electrolyser as shown in figure 3.

- Install both overflow tanks.
- Attach both tubes to the connections on the tanks.
 - Use tubes with an inside diameter of 4 mm to supply the H-TEC EDUCATION fuel cells having connections with an outside diameter of 5 mm.
 - Use tubes with an inside diameter of 5 mm to supply the H-TEC EDUCATION fuel cells having connections with an outside diameter of 6 mm.
- Fit both tube clamps on the tubes.

Filling

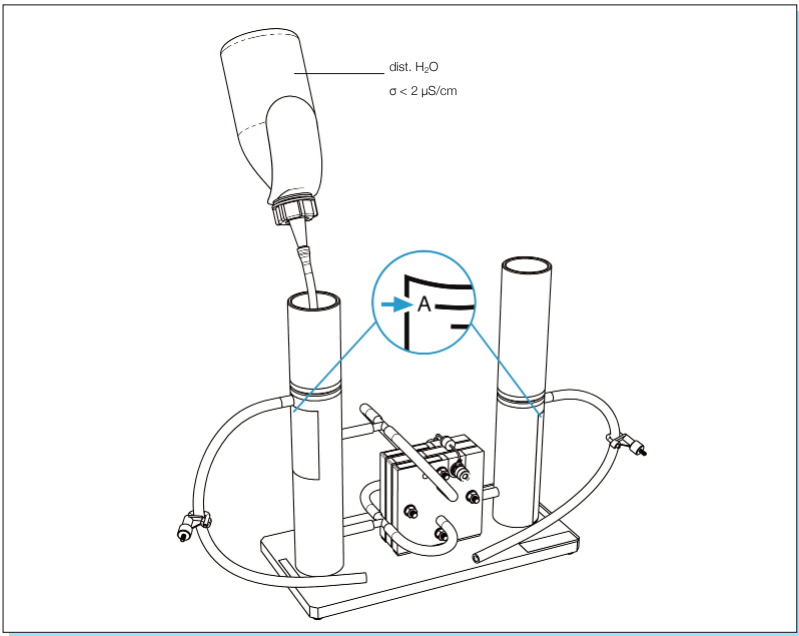

Fig. 4: Filling

- Open both tube clamps on the tubes.
- Fill both gas storage tanks with distilled water to the -A- mark ($\sigma < 2 \mu\text{S/cm}$) as shown in figure 4.

Operation

 **CAUTION**

Risk of injury from hydrogen ignition

Damaged tubes or leaking connections can cause hydrogen to leak. Hydrogen and hydrogen-air mixtures can ignite when in proximity to an ignition source.

Check tubes and connections for damage before each setup.

 **CAUTION**

Risk of injury from hot surfaces

The protection diode on the electrolyser becomes very hot in case of incorrect polarity.

Touching the diode on the electrolyser may cause injuries. Before starting up, ensure correct polarity of the connecting cables and the electrical connections (red = "+", black = "-"). Do not touch the diode.

 **CAUTION**

Risk of injury from hydrogen ignition

Escaping hydrogen can ignite when in proximity to an ignition source.

Prevent hydrogen from escaping. Completely use up all hydrogen at the end of experiments and before dismantling.

 **CAUTION**

Risk of fire due to electrical overload

Any operation beyond the electrical specifications will lead to excessive overheating of the electrolyser. This can cause a fire.

Never operate the electrolyser beyond the electrical specifications stated in the technical data.

CAUTION

Risk of damage due to improper handling

Operating the electrolyser using water with an electrical conductivity of $\geq 2 \mu\text{S/cm}$ will cause irreparable damage to the electrolyser. Only fill the electrolyser using distilled water with an electrical conductivity of $< 2 \mu\text{S/cm}$.

CAUTION

Risk of damage due to electrical overload

Any operation beyond the electrical specifications will lead to irreparable damage to the electrolyser.

Never operate the electrolyser beyond the electrical specifications stated in the technical data.

- Read and observe the general safety instructions.
- Close both tube clamps.
- Connect a DC voltage source to the connection jacks of the electrolyser. Observe the maximum permissible operating voltage (refer to the technical data).
- After each refill with distilled water, the residual air must be purged from the system once. To do this, produce 40 cm³ of hydrogen and 20 cm³ of oxygen, and release the gasses by briefly opening both tube clamps. After purging, the electrolyser is ready for operation.
- When the gas storage tanks are filled, excess gas escapes as bubbles. Gas production must then be stopped.
- During operation, small amounts of water pass through the PEM from the oxygen side to the hydrogen side. This can cause the water level to rise on the hydrogen side and fall on the oxygen side. Check and adjust the water level regularly. To this end, the water on the hydrogen side must be removed and supplied to the oxygen side.
- During operation, the distilled water is consumed. Pay attention to the water level and regularly top up with a little distilled water.

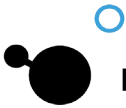

Technical Data

E206:

Item name: Electrolyser H₂/O₂ 65
Item no: E206
H x W x D: 250 x 250 x 120 mm
Weight: 950 g
Number of cells: 2
Electrode dimensions: 40 x 40 mm
Operating medium: distilled water, $\kappa < 2 \mu\text{S}/\text{cm}$
Fill volume H₂O, H₂-side: approx. 90 ml
Fill volume H₂O, O₂-side: approx. 130 ml
Permissible operating voltage: 0 - 4.0 VDC
Permissible operating current: 0 - 4.4 A
Rated power consumption: approx. 16 W
Gas production H₂ at rated power output:.....approx. 65 cm³/min
Gas production O₂ at rated power output:.....approx. 32.5 cm³/min
Gas storage volume H₂: 80 cm³
Gas storage volume O₂: 40 cm³
Permissible operating pressure: 0 - 20 mbar

E207:

Item name: Electrolyser H₂/O₂ 230
Item no: E207
H x W x D: 250 x 330 x 200 mm
Weight: 1850 g
Number of cells: 7
Electrode dimensions: 40 x 40 mm
Operating medium: distilled water, $\kappa < 2 \mu\text{S}/\text{cm}$
Fill volume H₂O, H₂-side: approx. 90 ml
Fill volume H₂O, O₂-side: approx. 130 ml
Permissible operating voltage: 0 - 14.0 VDC
Permissible operating current: 0 - 4.4 A
Rated power consumption: approx. 56 W
Gas production H₂ at rated power output:.....approx. 230 cm³/min
Gas production O₂ at rated power output:.....approx. 115 cm³/min
Gas storage volume H₂: 80 cm³
Gas storage volume O₂: 40 cm³
Permissible operating pressure: 0 - 20 mbar

Troubleshooting

The power supply is connected, but no gas is produced in the electrolyser.

Possible cause:

- The electrical input power is too low.

Solution:

- Check the input power. Increase the input voltage or input current up to the upper limits stated in the technical data as a maximum.

The power supply is connected and there is gas production, but no gas is stored in the electrolyser.

Possible cause 1:

- The tube clamps are not closed.

Solution:

- Close the tube clamps.

Possible cause 2:

- The overflow tanks are not secured firmly in place.

Solution:

- Secure the overflow tanks firmly in place.

Despite being set up correctly, the electrolyser is not working.

Possible cause:

- No distilled water was used. The electrolyser has sustained irreparable damage.

If the above-mentioned solutions do not eliminate the cause of the error, please contact H-TEC EDUCATION.

Shutting down

CAUTION

Risk of injury from hydrogen ignition

Escaping hydrogen can ignite when in proximity to an ignition source. Prevent hydrogen from escaping. Completely use up all hydrogen at the end of experiments and before dismantling.

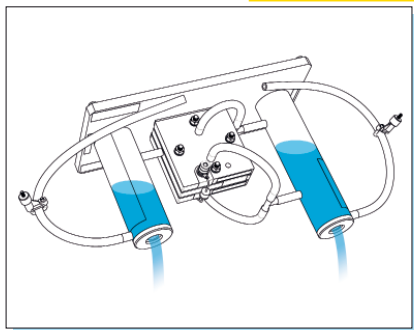

Fig. 5: Draining the water

- Stored gases have to be consumed before draining the storage tanks.
- Close both tube clamps.
- Unscrew both overflow tanks.
- Drain the water from the gas storage tanks, as shown in figure 5.

Figure 5 is an example only and is applicable to both models. The work steps are identical.

Before putting the product into storage, observe the following points:

Carefully remove any water drops from the product using a soft, lint-free cloth. This prevents the formation of water stains.

Maintenance

The components of this product do not require maintenance. The following points should be observed, however:

- Use fresh distilled water for each new start-up.
- After operation, remove the water from the gas storage tanks.

Transport and storage

With regard to transport and storage of the product, the following points should be observed to ensure a long service life. Transport and storage only:

- In the original packaging
- Dry and dust-free
- At temperatures from 4 °C to 50 °C
- Protected from vibrations

Disposal

Do not dispose of electrolyzers as general household waste.



Risk of fire due to catalytic substances

The catalysts for the electrodes of fuel cells and electrolyzers promote burning when they come into contact with flammable substances.

Avoid contact with hydrogen, alcohol fumes or other organic fumes. Ensure correct disposal.

According to European regulations, used electric and electronic devices may not be disposed of as unsorted household waste. The symbol of the crossed-out wheelee bin indicates the requirement for separate disposal.

Your local waste management company can provide you with additional information about disposal options.

Notes

Notes



© H-Tec Education, 2019. No part of this guide may be reproduced in whole or in part in any manner without the express written permission of H-Tec Education.
Subject to technical changes.