

# Operating Instructions



**T203** - TUTORIAL PRO

## Table of contents

<b>03</b>	The TUTORIAL Set
<b>03</b>	About these instructions
<b>03</b>	Safety information
<b>04</b>	Content
<b>07</b>	About the experiments
<b>09</b>	Experiment 1: Solar Power
<b>12</b>	Experiment 2: Solar hydrogen generation and storage
<b>16</b>	Experiment 3: Solar hydrogen system - H <sub>2</sub> /O <sub>2</sub>
<b>20</b>	Experiment 4: Solar hydrogen system - H <sub>2</sub> /Air
<b>24</b>	Experiment 5: Fuel cell vehicle and solar hydrogen filling station
<b>29</b>	Experiment 6: Modular fuel cell
<b>35</b>	Technical data
<b>36</b>	Troubleshooting
<b>38</b>	Shutting down
<b>38</b>	Maintenance
<b>38</b>	Transport and storage
<b>39</b>	Disposal

## The TUTORIAL Set

The predicted climate change in combination with the worldwide rising energy demand and the decreasing coal, oil and gas resources make the development of new energy sources one of the main tasks of the 21st century. Hydrogen technology plays a special role here. Hydrogen and oxygen can be used to directly generate electricity with the use of fuel cells. The only emission: water. Using electricity (e.g. provided by solar cells), the required hydrogen can be generated directly from water by splitting it into hydrogen and oxygen. The principle behind this is referred to as electrolysis. Together, the two processes form the solar-hydrogen cycle.

All stages of the solar-hydrogen cycle can be clearly explained using simple experiments. This is a simple principle, which works in small and large scale while protecting resources and relieving the strain on the environment. It is not a surprise then that all experts predict excellent future prospects for fuel cell technology.

These instructions explain the assembly, startup and function of the set. Furthermore, you will find numerous experiments and suggestions for using the devices in class.

We hope you conduct exciting experiments and gain interesting insights into the future of energy supply.

The team at,  
H-TEC EDUCATION

## About these instructions

- These operating instructions are intended for the supervisor in charge.
- These operating instructions have to be read and observed before use.
- These operating instructions have to be available for reference and have to be stored in a safe place.
- All safety instructions must be observed.
- This product may only be put into operation and operated under the directions of the responsible supervisor.

## Safety information

Read and observe the general safety instructions included separately with this product before using the product!

Product-specific safety information

The product may only be used:

- according to the intended use
- in compliance with all safety information



1x fuel cell with transport tubes and stopper  
 1x electrolyzer with transport tubes



1x modular fuel cell  
 1x tool set consisting of:  
 1x spanner  
 1x hex socket key  
 1x tweezers

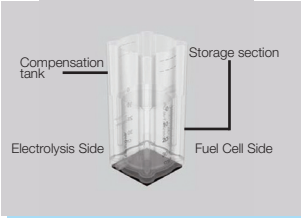

2x gas storage tank



1x solar module



1x fan

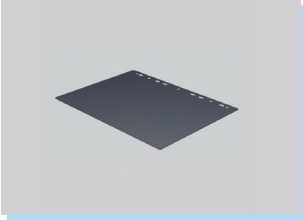

1x experimentation plate

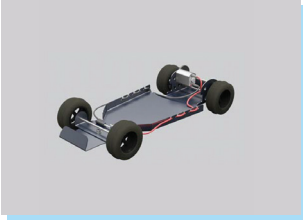

1x vehicle plate



1x cable set consisting of:

2x connection cable, 2mm, length 25 cm, red  
2x connection cable, 2mm, length 25 cm, black  
1x connection cable, 2 mm, length 50 cm, red  
1x connection cable, 2 mm, length 50 cm, black

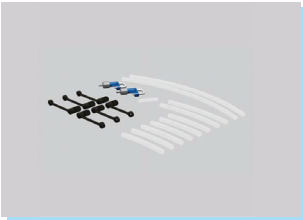

1x tube set consisting of:

6x tube, short (6 cm)  
2x tube, medium (9 cm)  
2x tube, long (20 cm)  
2x tube clamp  
1x connection tube  
6x cap



1x bottle for distilled water



1x transport box with insert



1x textbook  
*Fuel Cell Technology for Classroom Instruction*  
1x operating instructions



Detail View:  
Cap for gas connection  
Stopper for closing off air intake

## About the experiments

The following section contains general warning information and comments on the experiments.

### General warning information:

#### CAUTION

Risk of damage to the equipment from voltage. Applying voltage to a fuel cell or a solar module leads to irreparable damage to the components.

Do not apply voltage to fuel cells and solar modules.

### Using the gas storage tanks:

The gas storage tanks have a graduated storage section and two fill level markings on the compensation tank. The lower marking has to be used when the gas storage tanks are used in connection with a fuel cell. The upper marking is only intended for pure electrolysis operation.

Always observe the respective setup instructions for filling the gas storage tanks. For draining the gas storage tank, refer to the chapter “Shutting down”.

#### CAUTION

Risk of injury from hydrogen ignition

Escaping hydrogen can ignite in proximity to an ignition source.

Prevent hydrogen from escaping. Completely use up all hydrogen at the end of experiments, before dismantling.

## Using the experiment templates

All components are equipped with magnets. When the experiment templates are placed on the metal experimentation plate in the folder, the experiments can be set up safely and easily. Place the components on the marked positions on the experiment templates as described in the setup instructions.

H-TEC EDUCATION fuel cells and electrolyzers are clearly marked with colors depending on their function.

**Blue:** Electrolyzer



Frequently used abbreviations

**FC:** Fuel Cell

**EL:** Electrolyzer

**Red:** Fuel Cell



**PEM:** Proton Exchange Membrane



## Experiment 1: Solar energy

---

### Overview

The objective of the experiment is to convert light energy into electrical energy using the solar module. The electrical consumer is used for illustration purposes.

Setup time: approx. 1 minute

Duration of the experiment: approx. 1 minute

---

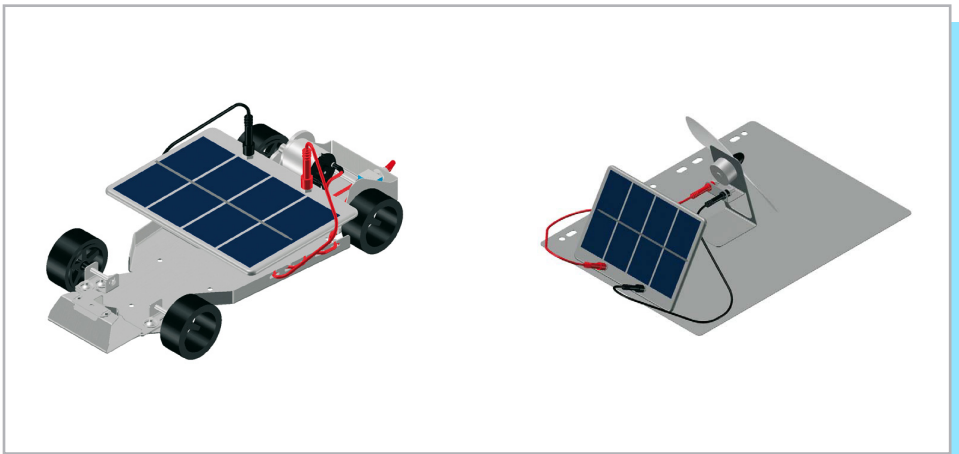

### Devices and material

The following is required for the experiment:

- 1x solar module
- 1x fan
- 1x experimentation plate or vehicle plate
- 1x suitable light source
- 2x connecting cable 2 mm
- Safety adapter 2 mm to 4 mm, if necessary

### Setup/assembly

1 . Place the solar module and the fan on the experimentation plate (fig. 1) or place the solar module on the vehicle plate (fig. 2) as marked.

2 . Connect the solar module to the corresponding connections on the fan or to the motor cables on the experimentation plate using the connecting cables. Ensure correct polarity (red = “+”, black = “-”).

#### CAUTION

##### Risk of injury from hot surfaces!

The surface of solar modules can become very hot during operation. Touching the surface of solar modules may cause injuries. Do not touch the surface of solar modules during operation. Let the surface of the solar modules cool to 60 °C before removing.

#### CAUTION

##### Risk of damage through insufficient distance to lamps

The solar module can become excessively hot or sustain irreparable damage if it is too close to the lamp. Observe the minimum distance defined by the manufacturer when operating solar modules with lamps.

#### NOTE

##### Further information

Further information for carrying out the experiments and for troubleshooting can be found in the chapters “About the experiments” and “Troubleshooting”.

3 . When the solar module receives enough light, the fan or the motor starts to run.

4 . Disassemble the experiment as described in chapter “Shutting down”.

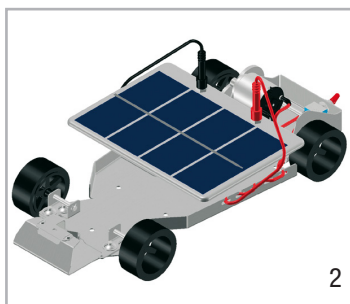
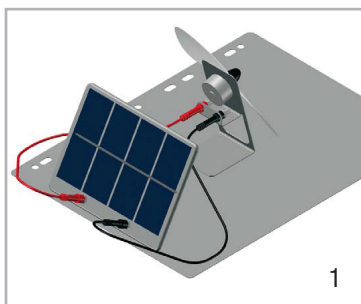



Consumer

### Experiment 1

Solar energy

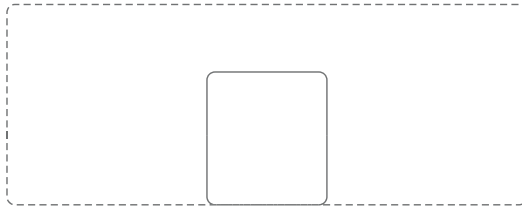

Solar module

## Experiment 2: Solar hydrogen generation and storage

### Overview:

The objective of the experiment is to operate the electrolyzer with the generated energy. The electrolyzer splits water into the gases hydrogen and oxygen which are stored in the respective gas storage tanks.

Setup time: approx. 3 minutes

Duration of the experiment: approx. 5-15 minutes

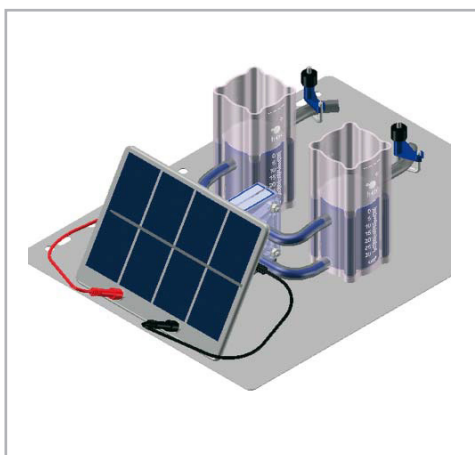

### Devices and material

The following is required for the experiment:

- 1x electrolyzer
- 2x gas storage tank
- 1x solar module
- 1x experimentation plate
- 1x tube set (4x short, 2x long)
- 2x tube clamp
- 1x bottle with distilled water
- 1x suitable light source
- 2x connecting cable 2 mm
- Safety adapter 2 mm to 4 mm, if necessary

**Setup/assembly**

1 . Place the two gas storage tanks and the electrolyzer on the experimentation plate as marked.

 **CAUTION**

**Risk of injury from hydrogen ignition**  
 Damaged tubes or leaking connections can cause hydrogen to leak. Incorrect connection of the tubes can lead to formation of an explosive hydrogen-air mixture. Hydrogen and hydrogen-air mixtures can ignite in proximity to an ignition source. Check tubes and connections for damage before each setup. The tubes have to be connected exactly as described in the instructions.

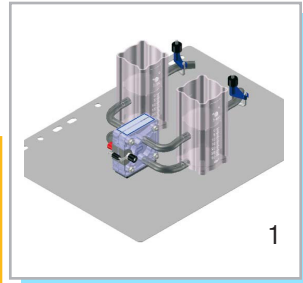

2 . Connect the upper and lower connections of the electrolyzer to the corresponding connections on the electrolysis side of the gas storage tanks with four short tubes.

3 . Place one long tube on the connection of the fuel cell side of each of the gas storage tanks and close each off with a tube clamp (fig. 1).

4 . Fill both gas storage tanks with distilled water to the upper marking of the compensation tanks.

5 . Open the tube clamps. The air escapes from the gas storage tanks and the electrolyzer. The process is completed when the water level in the gas storage tanks no longer decreases (fig. 2). Then close off both tube clamps again.

6 . Connect the solar module to the corresponding connections on the electrolyzer using the connecting cables (fig. 3). Ensure the correct polarity (red = "+", black = "-")!

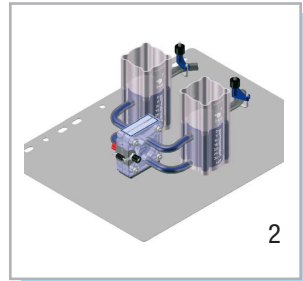
 **CAUTION**

**Risk of injury from hot surfaces!**  
 The protection diode on the electrolyzer becomes very hot in case of incorrect polarity. Touching the surface of the diode can cause injuries. Before startup, ensure correct polarity of the connecting cables and the electrical connections (red = "+", black = "-")! Do not touch the diode.

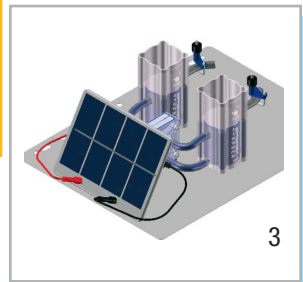

## Gas generation

1 . When the solar module receives enough light, the electrolyzer starts producing hydrogen and oxygen at a ratio of 2:1 (fig. 4).

### CAUTION

Risk of injury from hot surfaces!  
The protection diode on the electrolyzer becomes very hot in case of incorrect polarity. Touching the surface of the diode can cause injuries. Before startup, ensure correct polarity of the connecting cables and the electrical connections (red = “+”, black = “-“)! Do not touch the diode.

### CAUTION

Risk of damage through insufficient distance to lamps The solar module can become excessively hot or sustain irreparable damage if it is too close to the lamp. Observe the minimum distance defined by the manufacturer when operating solar modules with lamps.

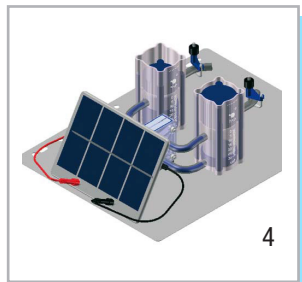

2 . When the gas storage tanks are filled, excess gas escapes as bubbles. Hydrogen production has to be stopped.

### CAUTION

Risk of injury from hydrogen ignition  
Escaping hydrogen can ignite in proximity to an ignition source. Prevent hydrogen from escaping. Stopping hydrogen production.

### NOTE

Further information  
Further information for carrying out the experiments and for troubleshooting can be found in the chapters “About the experiments” and “Troubleshooting”.

3 . Continue operating the fuel cells until the consumer (e.g. the motor) stops independently. This allows some water to remain in the fuel cell, moistening the PEM. This procedure also prevents unnecessary discharge of hydrogen.

### CAUTION

Risk of injury from hydrogen ignition  
Escaping hydrogen can ignite in proximity to an ignition source. Prevent hydrogen from escaping. Completely use up all hydrogen at the end of experiments, before dismantling.

4 . Disassemble the experiment as described in chapter “Shutting down”.

## Experiment 2

Solar hydrogen generation and storage

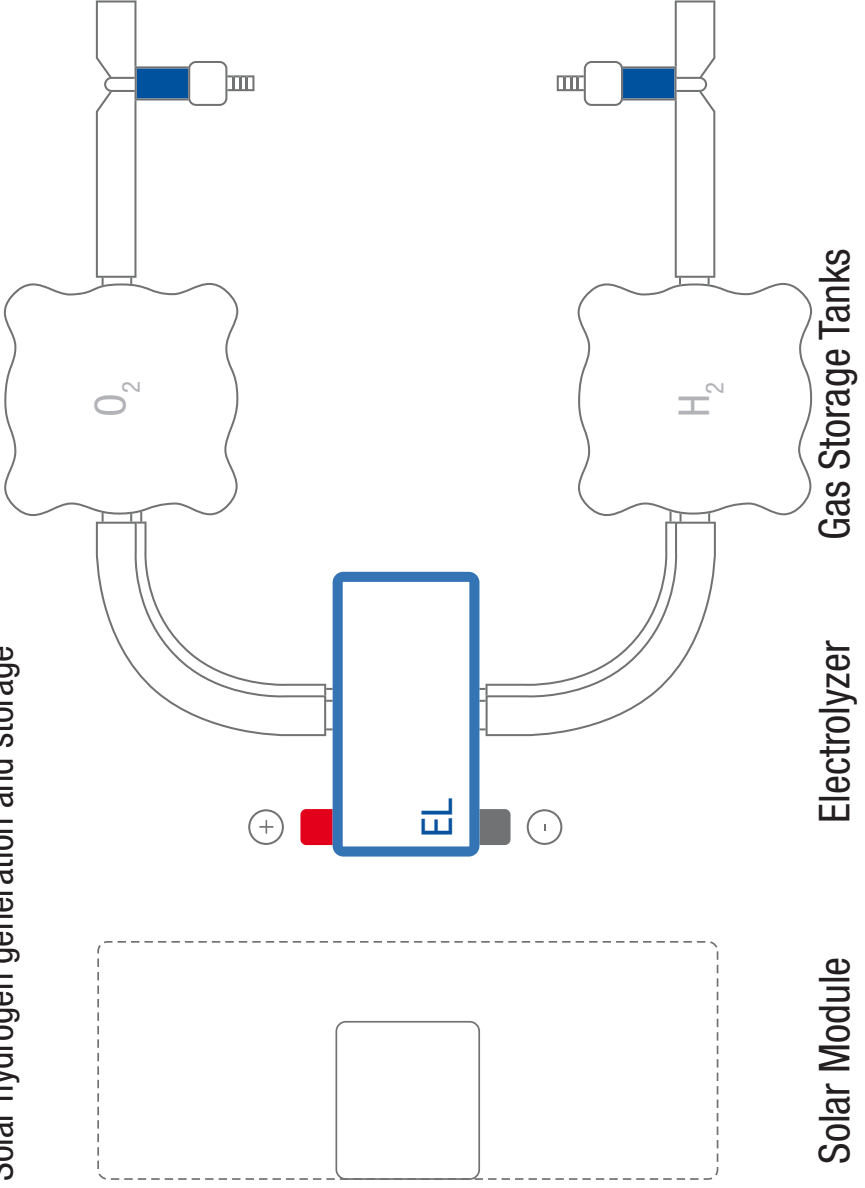

## Experiment 3: Solar hydrogen system - $H_2/O_2$

### Overview

The objective of the experiment is to generate electrical energy from the stored gases. The gases are fed to the fuel cell. The fuel cell converts the chemical energy into electricity and heat. The electrical consumer is used for illustration purposes.

Setup time: approx. 5 minutes

Duration of the experiment: approx. 10 minutes

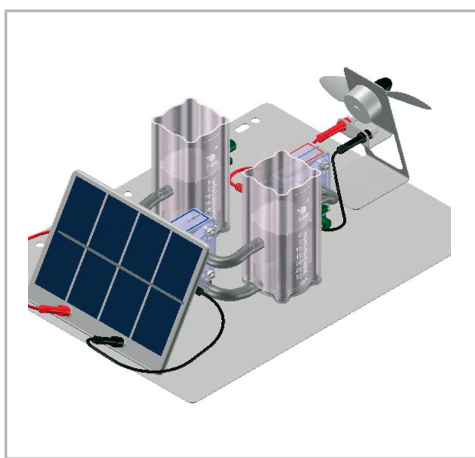

### Devices and material

The following is required for the experiment:

- 1x electrolyzer
- 1x fuel cell
- 2x gas storage tank
- 1x solar module
- 1x fan
- 1x experimentation plate
- 1x tube set (6x short)
- 1x stopper
- 2x cap
- 1x bottle with distilled water
- 1x suitable light source
- 4x connecting cable 2 mm
- safety adapter 2 mm to 4 mm, if necessary



**Setup/assembly**

1 . Place the two gas storage tanks and the electrolyzer on the experimentation plate as marked.

 **CAUTION**

**Risk of injury from hydrogen ignition**  
 Damaged tubes or leaking connections can cause hydrogen to leak. Incorrect connection of the tubes can lead to formation of an explosive hydrogen-air mixture. Hydrogen and hydrogen-air mixtures can ignite in proximity to an ignition source. Check tubes and connections for damage before each setup. The tubes have to be connected exactly as described in the instructions.

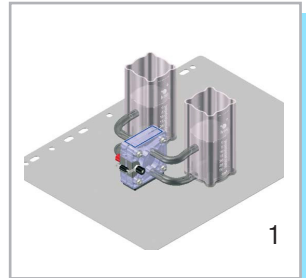

2 . Connect the upper and lower connections of the electrolyzer to the corresponding connections on the electrolysis side of the gas storage tanks with four short tubes (fig. 1).

3 . Place the fuel cell on the experimentation plate. Connect the upper connections of the fuel cell to the connection on the fuel cell side of the gas storage tanks using two short tubes. The stopper of the fuel cell has to be inserted.

4 . Close each of the two lower connections of the fuel cell with a cap (fig. 2).

5 . Fill both gas storage tanks with distilled water to the lower marking of the compensation tanks.

6 . Open the caps on both sides of the fuel cell so that the air escapes from gas storage tanks, electrolyzer and fuel cell. The process is completed when the water level in the gas storage tanks no longer decreases (fig. 3). Then close the lower connections of the fuel cell with the caps again.

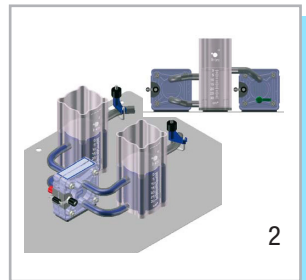
**NOTE**

**Water in the fuel cell**  
 Ensure that no water runs into the fuel cell. A water film on the electrode surface can suppress the reaction of hydrogen and oxygen in the fuel cell. The fuel cell then does not have sufficient power.

7 . Place the solar module on the experimentation plate as marked and connect it to the corresponding connections on the electrolyzer using the connecting cables (fig. 4). Ensure the correct polarity (red = "+", black = "-")!

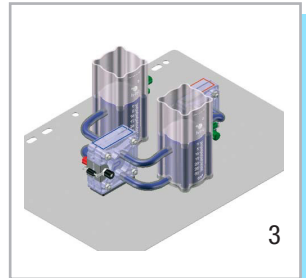
 **CAUTION**

**Risk of injury from hot surfaces!**  
 The protection diode on the electrolyzer becomes very hot in case of incorrect polarity. Touching the surface of the diode can cause injuries. Before startup, ensure correct polarity of the connecting cables and the electrical connections (red = "+", black = "-")! Do not touch the diode.

8 . Place the fan on the experimentation plate as marked and connect it to the corresponding connections on the fuel cell using the connecting cables. Ensure correct polarity (red = "+", black = "-").

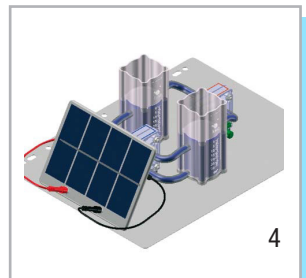

## Gas generation

1 . When the solar module receives enough light, the electrolyzer starts producing hydrogen and oxygen at a ratio of 2:1 (fig. 5).

### CAUTION

**Risk of injury from hot surfaces!**  
The surface of solar modules can become very hot during operation. Touching the surface of solar modules may cause injuries. Do not touch the surface of solar modules during operation. Let the surface of the solar modules cool to 60 °C before removing.

### CAUTION

**Risk of damage through insufficient distance to lamps.** The solar module can become excessively hot or sustain irreparable damage if it is too close to the lamp. Observe the minimum distance defined by the manufacturer when operating solar modules with lamps.

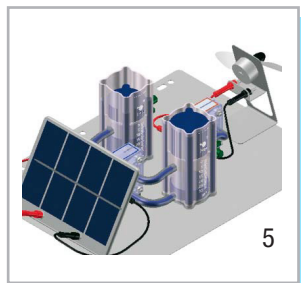

2 . When the gas storage tanks are filled, excess gas escapes as bubbles. Hydrogen production has to be stopped.

### CAUTION

**Risk of injury from hydrogen ignition**  
Escaping hydrogen can ignite in proximity to an ignition source. Prevent hydrogen from escaping. Stopping hydrogen production.

## Starting up the fuel cell

Carry out the following steps to purge the remaining air from the tubes and the fuel cell:

- 1 . Briefly open the caps at both sides of the fuel cell one after the other so that 10 cm<sup>3</sup> of the stored gases can flow through the fuel cell.
- 2 . Then close the respective cap again. The fan starts rotating.

### NOTE

**Draining the oxygen storage tank**  
The cap at the outlet of the oxygen storage tank has to be opened at the end of each experiment to remove the oxygen from the oxygen storage tank. Then close the cap again.

### NOTE

**Further information**  
Further information for carrying out the experiments and for troubleshooting can be found in the chapters “About the experiments” and “Troubleshooting”.

3 . Continue operating the fuel cell until the consumer (e.g. the motor) stops independently. This allows some water to remain in the fuel cell, moistening the PEM. This procedure also prevents unnecessary discharge of hydrogen.

### CAUTION

**Risk of injury from hydrogen ignition**  
Escaping hydrogen can ignite in proximity to an ignition source. Prevent hydrogen from escaping. Completely use up all hydrogen at the end of experiments, before dismantling.

4 . Disassemble the experiment as described in chapter “Shutting down”.

### Experiment 3

Solar hydrogen generation system -

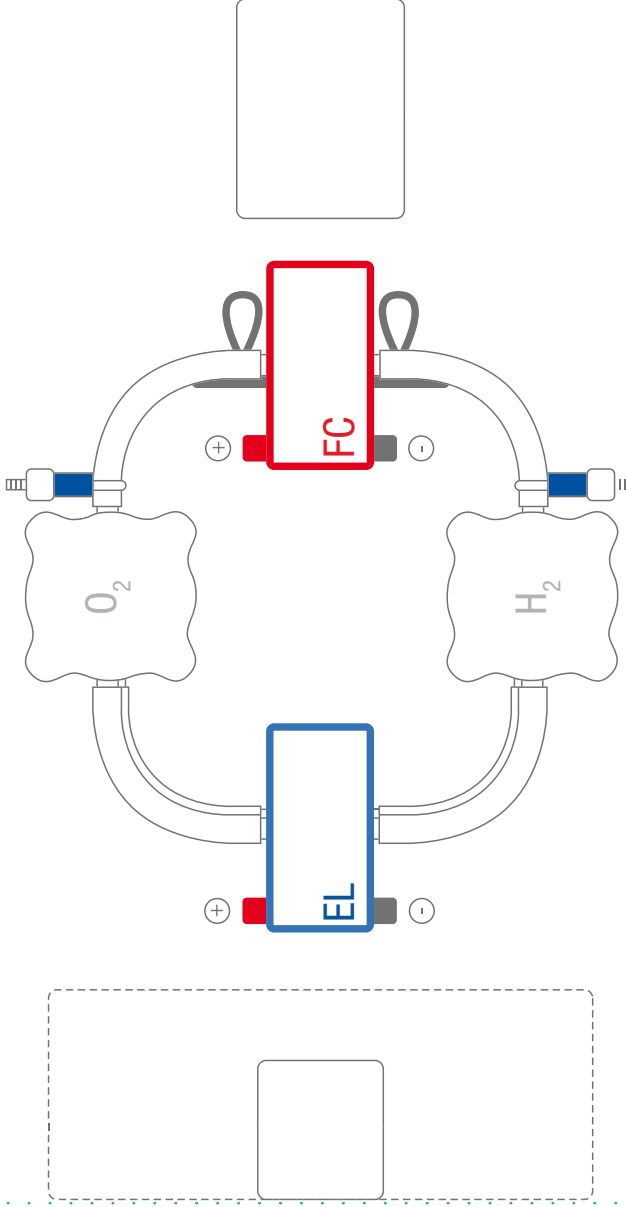

Solar Module

Electrolyzer

Gas Storage Tanks

Fuel Cell

Load

## Experiment 4: Solar hydrogen system - H<sub>2</sub>/Air

### Overview

The objective of the experiment is to generate electrical energy from the stored hydrogen and atmospheric oxygen. The hydrogen is fed to the fuel cell. The fuel cell converts the chemical energy into electricity and heat. The electrical consumer is used for illustration purposes.

Setup time: approx. 5 minutes

Duration of the experiment: approx. 10 minutes

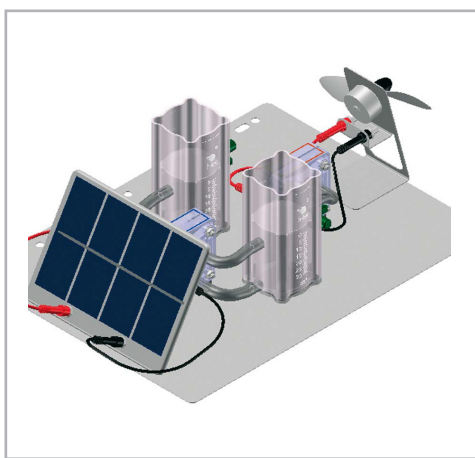

### Devices and material

The following is required for the experiment:

- 1x electrolyzer
- 1x fan
- 1x suitable light source
- 1x tube attachment
- 1x experimentation plate
- 4x connecting cable 2 mm
- 2x gas storage tank
- 1x tube set (5x short)
- safety adapter 2 mm to 4 mm, if necessary
- 1x solar module
- 2x cap
- 1x bottle with distilled water

**Setup/assembly**

1 . Place the two gas storage tanks and the electrolyzer on the experimentation plate as marked.

 **CAUTION**

Risk of injury from hydrogen ignition  
 Damaged tubes or leaking connections can cause hydrogen to leak. Incorrect connection of the tubes can lead to formation of an explosive hydrogen-air mixture. Hydrogen and hydrogen-air mixtures can ignite in proximity to an ignition source. Check tubes and connections for damage before each setup. The tubes have to be connected exactly as described in the instructions.

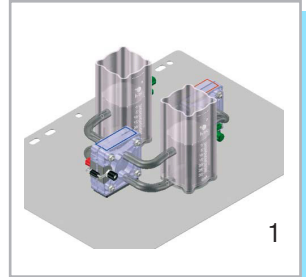

2 . Connect the upper and lower connections of the electrolyzer to the corresponding connections on the electrolysis side of the gas storage tanks with four short tubes (fig. 1).

3 . Place the fuel cell on the experimentation plate. Connect the upper connection of the fuel cell on the hydrogen side to the connection on the fuel cell side of the hydrogen storage tank using a short hose (fig. 2). The stopper of the fuel cell must not be inserted.

4 . Close the lower connection of the fuel cell on the hydrogen side and the connection on the fuel cell side of the oxygen storage tank with one cap each.

5 . Fill both gas storage tanks with distilled water to the lower marking of the compensation tanks.

6 . Open the cap on the fuel cell and the cap on the oxygen storage tank so that the air escapes from gas storage tanks, electrolyzers and fuel cell. The process is completed when the water level in the gas storage tank no longer decreases (fig. 3). Then place the cap on the oxygen storage tank and the cap on the fuel cell on the corresponding connections again.

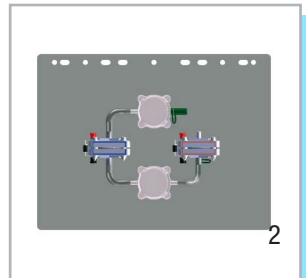
**NOTE**

Water in the fuel cell  
 Ensure that no water runs into the fuel cell. A water film on the electrode surface can suppress the reaction of hydrogen and oxygen in the fuel cell. The fuel cell then does not have sufficient power.

7 . Place the solar module on the experimentation plate as marked and connect it to the corresponding connections on the electrolyzer using the connecting cables (fig. 4). Ensure the correct polarity (red = "+", black = "-")!

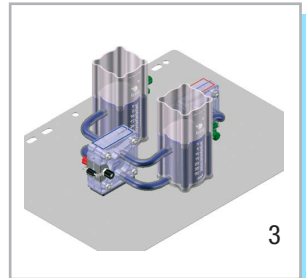
 **CAUTION**

Risk of injury from hot surfaces!  
 The protection diode on the electrolyzer becomes very hot in case of incorrect polarity. Touching the surface of the diode can cause injuries. Before startup, ensure correct polarity of the connecting cables and the electrical connections (red = "+", black = "-")! Do not touch the diode.

8 . Place the fan on the experimentation plate as marked and connect it to the corresponding connections on the fuel cell using the connecting cables. Ensure the correct polarity (red = "+", black = "-")!

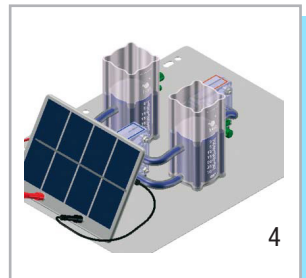

## Gas generation

1 . When the solar module receives enough light, the electrolyzer starts producing hydrogen and oxygen at a ratio of 2:1 (fig. 5).

### CAUTION

**Risk of injury from hot surfaces!**  
The surface of solar modules can become very hot during operation. Touching the surface of solar modules may cause injuries. Do not touch the surface of solar modules during operation. Let the surface of the solar modules cool to 60 °C before removing.

### CAUTION

**Risk of damage through insufficient distance to lamps.** The solar module can become excessively hot or sustain irreparable damage if it is too close to the lamp. Observe the minimum distance defined by the manufacturer when operating solar modules with lamps.

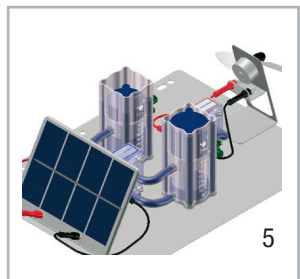

2 . When the gas storage tanks are filled, excess gas escapes as bubbles. Hydrogen production has to be stopped.

### CAUTION

**Risk of injury from hydrogen ignition**  
Escaping hydrogen can ignite in proximity to an ignition source. Prevent hydrogen from escaping. Stopping hydrogen production.

## Starting up the fuel cell

Carry out the following steps to purge the remaining air from the tubes and the fuel cell:

1 . Briefly open the caps at both sides of the fuel cell one after the other so that 10 cm<sup>3</sup> of the stored gases can flow through the fuel cell.

2 . Then close the respective cap again. The fan starts rotating.

### NOTE

**Draining the oxygen storage tank**  
The cap at the outlet of the oxygen storage tank has to be opened at the end of each experiment to remove the oxygen from the oxygen storage tank. Then close the cap again.

### NOTE

**Further information**  
Further information for carrying out the experiments and for troubleshooting can be found in the chapters “About the experiments” and “Troubleshooting”.

3 . Continue operating the fuel cell until the consumer (e.g. the motor) stops independently. This allows some water to remain in the fuel cell, moistening the PEM. This procedure also prevents unnecessary discharge of hydrogen.

### CAUTION

**Risk of injury from hydrogen ignition**  
Escaping hydrogen can ignite in proximity to an ignition source. Prevent hydrogen from escaping. Completely use up all hydrogen at the end of experiments, before dismantling.

4 . Disassemble the experiment as described in chapter “Shutting down”.

## Experiment 4

Solar hydrogen generation system -

$H_2$ /Air

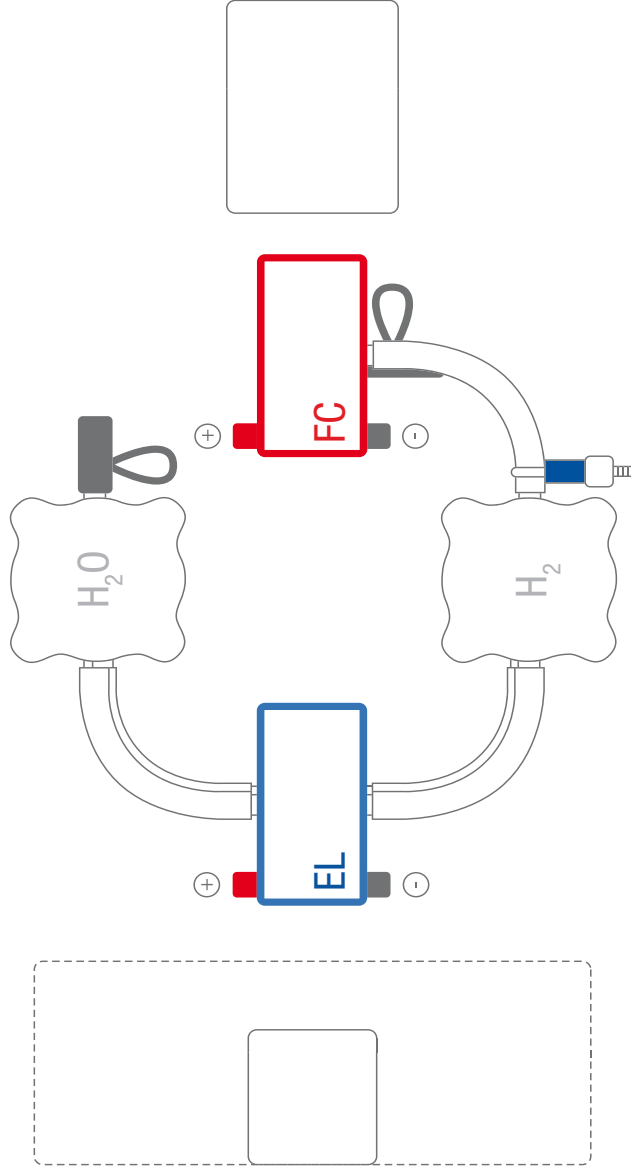

Solar Module

Electrolyzer

Gas Storage Tanks

Load

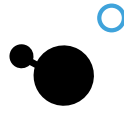

HTEC EDUCATION

## Experiment 5: Fuel cell vehicle and solar hydrogen filling

### Overview

The objective of the experiment is to use light energy to produce hydrogen. The electrolyzer splits water into the gases hydrogen and oxygen, whereby the hydrogen is stored for later use.

Setup time: approx. 3 minutes

Duration of the experiment: approx. 5-15 minutes

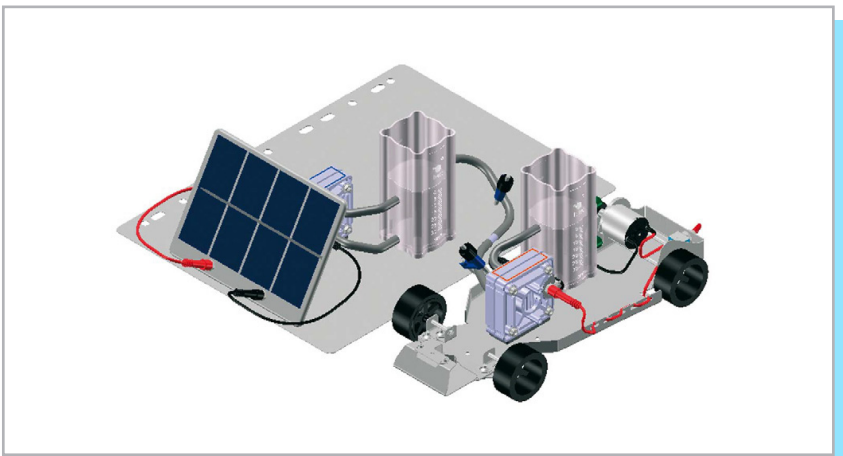

### Devices and material

The following is required for the experiment:

- 1x bottle with distilled water
- 1x tube attachment
- 1x electrolyzer
- 1x gas storage tank
- 1x solar module
- 1x experimentation plate
- 1x tube set (2x short, 1x long)
- 1x tube clamp
- 2x connecting cable 2 mm
- safety adapter 2 mm to 4 mm, if necessary
- 1x connection tube
- 1x suitable light source
- 1x fuel cell
- 1x vehicle plate
- 1x short tube
- 1x medium tube
- 1x tube clamp
- 2x cap



**Setup/assembly**

1 . Place one gas storage tank and the electrolyzer on the experimentation plate as marked.

 **CAUTION**

**Risk of injury from hydrogen ignition**  
 Damaged tubes or leaking connections can cause hydrogen to leak. Incorrect connection of the tubes can lead to formation of an explosive hydrogen-air mixture. Hydrogen and hydrogen-air mixtures can ignite in proximity to an ignition source.  
 Check tubes and connections for damage before each setup. The tubes have to be connected exactly as described in the instructions.

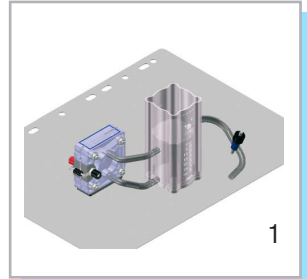

2 . Connect the electrolysis side of the gas storage tank to the connections on the hydrogen side of the electrolyzer with two short tubes. The gas storage tank serves as a hydrogen storage tank.

3 . Place one long tube on the connection of the fuel cell side of the hydrogen storage tank and close it off with a tube clamp (fig. 1).

4 . Fill the hydrogen storage tank with distilled water to the upper marking of the compensation tank.

5 . Open the tube clamp. The air escapes from the hydrogen storage tank and the electrolyzer. The process is completed when the water level in the hydrogen storage tank no longer decreases (fig. 2). Then close off the tube clamp again. 6 . Moisten the oxygen side of the electrolyzer with distilled water. To do this, screw the tube attachment onto the water bottle and connect the tube to the lower connection of the electrolyzer. Use light pressure on the bottle to flood the oxygen side of the electrolyzer with distilled water. Then remove the bottle again (fig. 3).

7 . Place the solar module on the experimentation plate as marked and connect it to the corresponding connections on the electrolyzer using the connecting cables (fig. 4). Ensure the correct polarity (red = "+", black = "-")!

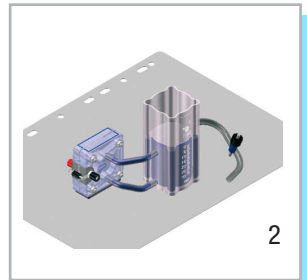
 **CAUTION**

**Risk of injury from hot surfaces!**  
 The protection diode on the electrolyzer becomes very hot in case of incorrect polarity. Touching the surface of the diode can cause injuries. Before startup, ensure correct polarity of the connecting cables and the electrical connections (red = "+", black = "-")! Do not touch the diode.

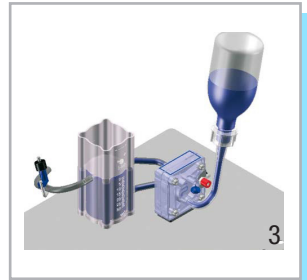
**Gas generation**

1 . When the solar module receives enough light, the electrolyzer starts producing hydrogen and oxygen at a ratio of 2:1, whereby the oxygen is not stored in this experiment.

 **CAUTION**

**Risk of injury from hot surfaces!**  
 The surface of solar modules can become very hot during operation. Touching the surface of solar modules may cause injuries. Do not touch the surface of solar modules during operation. Let the surface of the solar modules cool to 60 °C before removing.

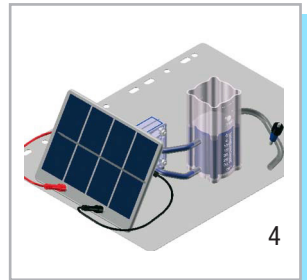

**CAUTION**

**Risk of damage through insufficient distance to lamps**  
 The solar module can become excessively hot or sustain irreparable damage if it is too close to the lamp. Observe the minimum distance defined by the manufacturer when operating solar modules with lamps.

2. When the hydrogen storage tank is filled, excess gas escapes as bubbles. Hydrogen production has to be stopped.

**CAUTION**

**Risk of injury from hydrogen ignition**  
 Escaping hydrogen can ignite in proximity to an ignition source. Prevent hydrogen from escaping. Stopping hydrogen production.

Setup/filling (fuel cell vehicle)

1. On the second gas storage tank, place two caps on the connections on the electrolysis side and a short tube on the fuel cell side. This serves as the hydrogen tank on the vehicle.

**CAUTION**

**Risk of injury from hydrogen ignition**  
 Damaged tubes or leaking connections can cause hydrogen to leak. Incorrect connection of the tubes can lead to formation of an explosive hydrogen-air mixture. Hydrogen and hydrogen-air mixtures can ignite in proximity to an ignition source. Check tubes and connections for damage before each setup. The tubes have to be connected exactly as described in the instructions.

2. Attach a medium tube with a tube clamp to the fuel cell on the hydrogen side on the lower connection. Close the tube clamp.

3. Connect the short tube on the hydrogen storage tank to the upper connection of the fuel cell on the hydrogen side.

4. Place the fuel cell and the hydrogen storage tank on the vehicle plate and connect the cables of the motor to the corresponding connections on the fuel cell. Ensure correct polarity (red = "+", black = "-"). (fig 5).

5. Fill the hydrogen storage tank with distilled water to the lower marking of the compensation tank.

6. Open the cap on the hydrogen side of the fuel cell so that the air escapes from the hydrogen storage tank and the fuel cell. The process is completed when the water level in the hydrogen storage tank no longer decreases (fig. 6). Then close the lower connection of the fuel cell with the cap again. The stopper of the fuel cell must not be inserted.

**NOTE**

**Water in the fuel cell**  
 Ensure that no water runs into the fuel cell. A water film on the electrode surface can suppress the reaction of hydrogen and oxygen in the fuel cell. The fuel cell then does not have sufficient power.

7. For filling, connect the two tubes from vehicle and filling station with the connection tube. Then open both tube clamps. A pressure compensation now occurs in the two hydrogen storage tanks so that both are half filled with hydrogen.

8. Close both tube clamps again and disconnect the tubes. The vehicle is now ready for operation. Ensure that the stopper on the oxygen side of the fuel cell is open.

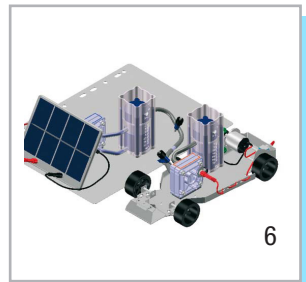
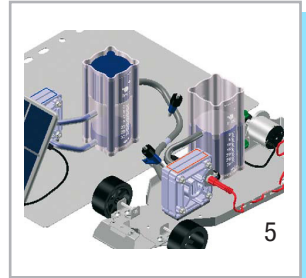

**NOTE**

Further information  
Further information for carrying out the experiments and for troubleshooting can be found in the chapters “About the experiments” and “Troubleshooting”.

9 . Set the switch at the back of the vehicle to “on”. The vehicle starts moving. To stop the vehicle, set the switch to “off” again.

10 . Continue operating the fuel cells until the consumer (e.g. the motor) stops independently. This allows some water to remain in the fuel cell, moistening the PEM. This procedure also prevents unnecessary discharge of hydrogen.

 **CAUTION**

Risk of injury from hydrogen ignition  
Escaping hydrogen can ignite in proximity to an ignition source. Prevent hydrogen from escaping. Completely use up all hydrogen at the end of experiments, before dismantling.

11 . Disassemble the experiment as described in chapter “Shutting down”.

## Experiment 5

Fuel cell vehicle and solar hydrogen filling station

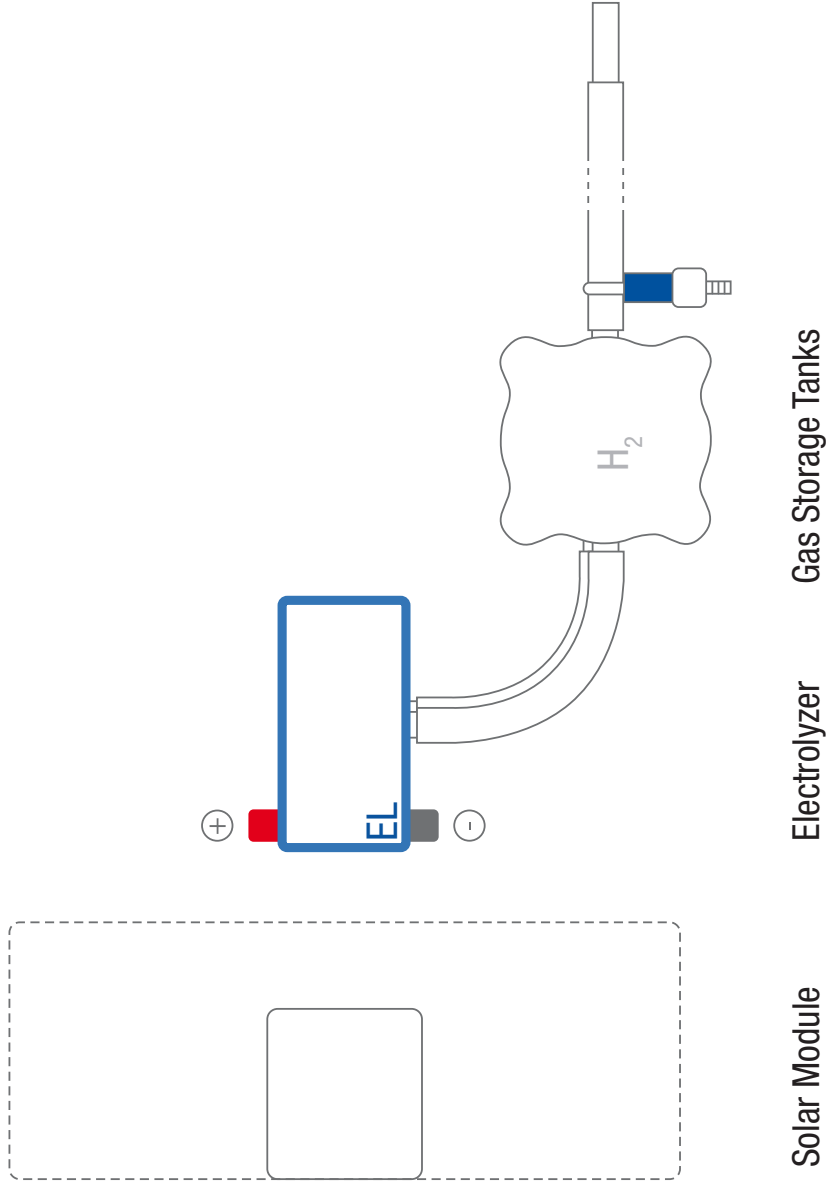

## Experiment 6: Modular fuel cell

### Overview

The aim of the experiment is to disassemble a fuel cell and to reassemble it from the individual components to understand the internal structure in a practical example.

Duration of the experiment: approx. 10 minutes



### Devices and material

The following is required for the experiment:

- 1x modular fuel cell
- 1x tool set
- 1x beaker filled with distilled water

## Individual Components

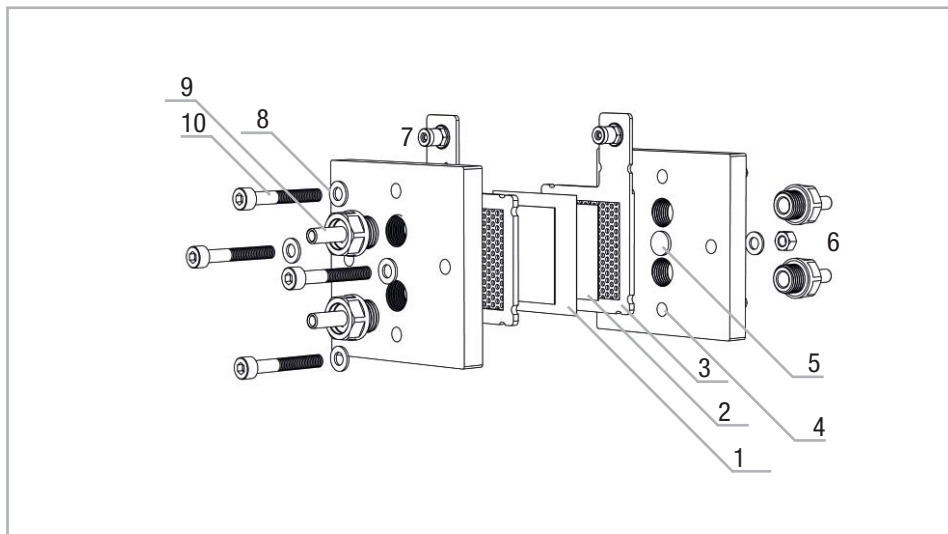

### Components

### Quantity

■ Position 1 polymer electrolyte membrane (PEM)	1
■ Position 2 electrodes	2
■ Position 3 current collector	2
■ Position 4 housing plates	2
■ Position 5 spacer (permanently connected to the housing)	2
■ Position 6 nuts	8
■ Position 7 connection jacks (permanently connected to the current collector)	2
■ Position 8 shims	8
■ Position 9 connection stubs	4
■ Position 10 screws	4

## Disassembly

The modular fuel cell can be fully disassembled.

### CAUTION

Fire hazard from catalytic substances  
The catalysts for the electrodes of the fuel cells promote burning when they come into contact with flammable substances. Avoid contact with hydrogen outside of the fuel cell, alcohol fumes or other organic fumes.

### CAUTION

Risk of damage to the equipment through improper handling The PEM and the electrodes are highly delicate components and can easily become damaged or contaminated.  
Handle the components with care. Prevent the components from being touched with fingers. Only handle the components in a clean environment with blunt plastic tweezers. Never touch the PEM with sharp objects.

### NOTE

Contamination through electrode material containing carbon The electrode material containing carbon can permanently contaminate the surface.

- 1 . Release the four nuts with the tool and remove the four screws holding the fuel cell together.
- 2 . Carefully separate the housing plates.

### NOTE

Stuck components  
The components of the fuel cell usually are not separate during disassembly but adhere together.

- 3 . Separate the current collectors or pull away from the housing plates.
- 4 . Use the tweezers to carefully pull the PEM off one of the current collectors.

### NOTE

Electrodes adhering to the PEM  
If the electrodes adhere to the PEM, carefully remove them with the tweezers.

- 5 . Place the PEM in a beaker with distilled water.
  - 6 . Use the tweezers to carefully remove the electrodes from the current collectors and place on a clean surface.
  - 7 . Use the tool to unscrew the four connection stubs from the two housing plates.
- Now the components are separated as shown in the above overview of the individual components.

## Assembly

### CAUTION

Risk of injury from hydrogen ignition  
Improper assembly of the fuel cell can cause leaks. Escaping hydrogen can ignite in proximity to an ignition source. Assembly of the fuel cell has to be carried out with the greatest care.

### CAUTION

Fire hazard from catalytic substances  
The catalysts for the electrodes of the fuel cells promote burning when they come into contact with flammable substances. Avoid contact with hydrogen outside of the fuel cell, alcohol fumes or other organic fumes.

### NOTE

Limited performance through dry membrane  
Before re-installation, the membrane has to soak in distilled water for at least five minutes.

1. Place a shim on each of the four screws and place in one of the two housing plates on the side facing away from the spaces. Then place the housing plate on a level surface with the screw heads facing down (fig. 1).

2. Place one of the two current collectors on the housing plate. For this, the thicker seal side has to face towards the housing plate (fig. 2).

3. Use the tweezers to place one of the two electrodes on the current collector. Make absolutely sure to observe the correct installation direction! The deep black side of the electrode has to face upwards, while the silvery black side of the electrode has to face down towards the current collector. Place the electrode so it is centered.

4. Remove the PEM from the distilled water with the tweezers. Place the wet PEM on the electrode so the PEM rests evenly on the sealing rim of the current collector all around. Ensure not to shift the electrode (fig. 3).

5. Place the second electrode on the PEM with the tweezers. Make absolutely sure to observe the correct installation direction! The deep black side of the electrode has to face upward. Place the electrode so it is centered.

6. Place the second current collector so the two connection jacks face in the same direction. The thicker sealing side faces upwards (fig. 4). The second electrode must not protrude into the sealing area during placement of the current collector. If necessary, correct the position of the electrode with the tweezers.

### NOTE

Advice for assembly  
We recommend holding on to the second current collector until the next step has been completed so it cannot shift after positioning.

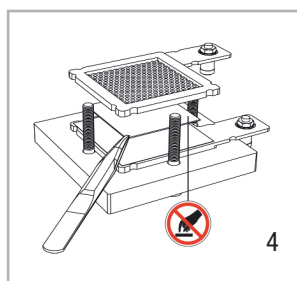
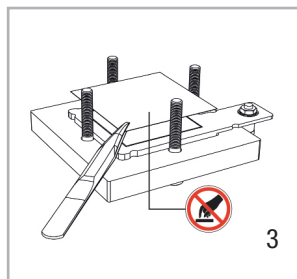
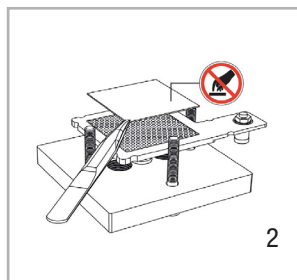
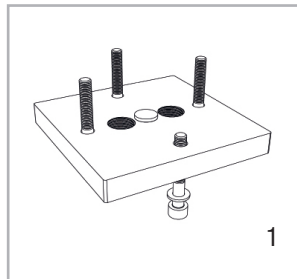



**NOTE**

**Advice for assembly**  
We recommend holding on to the second current collector until the next step has been completed so it cannot shift after positioning.

- 7 . Place the second housing plate with the spacer facing downwards (fig. 5).
- 8 . Place the four remaining shims on the screws. Place four nuts on the screws and screw the fuel cell together finger-tight.
- 9 . Keep tightening the nuts gradually(max 1/2 turn) (fig. 6) until the distance between the housing plates is approx. 4.0 mm.

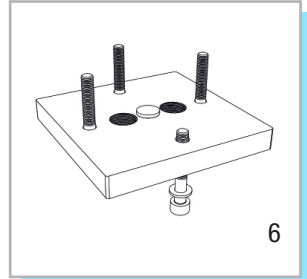

**CAUTION**

**Risk of damage from excessive tightening torque**  
Excessive tightening of the screws and nuts can cause damage to the electrodes.  
Check the distance between the housing plates with a caliper square or a similar tool.  
Never tighten the screws and nuts with great force!

- 10 . Screw the connecting stubs into the four openings in the housing plates.

**NOTE**

**Experiments with the fuel cell**  
Experiments 3 to 5 can also be carried out with the fully assembled fuel cell.

**NOTE**

**Operation with atmospheric oxygen**  
The connecting stubs have to be removed on one side for experiments 4 and 5.

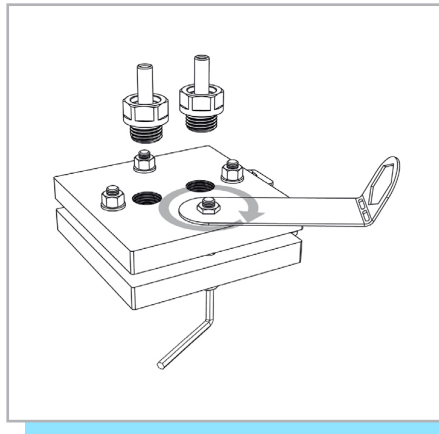

## Experiment 6

### Modular Fuel Cell

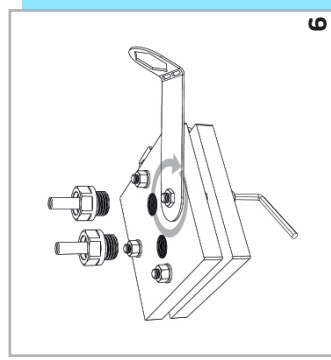
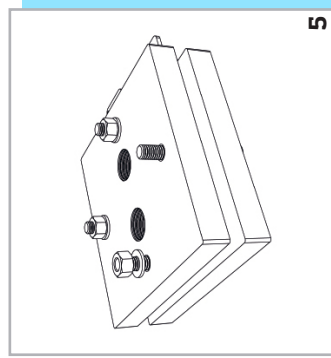
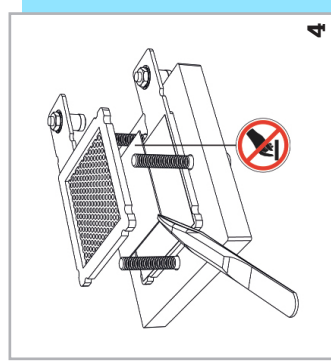
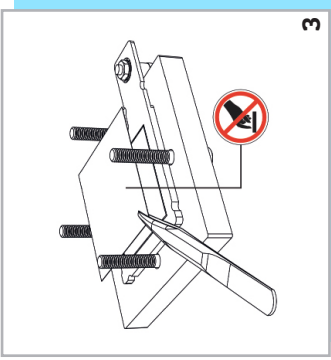
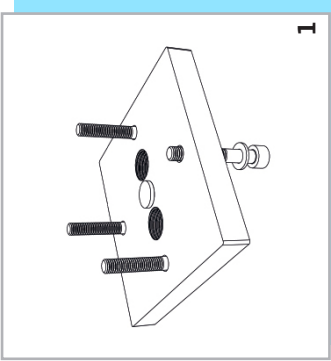

## Technical data

**Box:**

H x W x D:.....	400 x 300 x 180 mm
Weight:.....	3.25 kg

**Electrolyzer:**

H <sub>2</sub> Production:.....	10.0 mL/min
O <sub>2</sub> Production:.....	5 mL/min
Permissible Current:.....	0 - 1.5 A
Permissible operating voltage:.....	0 - 2.0 VDC
Electrode Area:.....	2.9 cm <sup>2</sup>
Guide value for distilled water:.....	<2 μS/cm
Permitted operating pressure:.....	0 - 20 mbar
H x W x D:.....	51 x 51 x 41 mm
Weight:.....	58 g

**Fuel Cell:**

H <sub>2</sub> / O <sub>2</sub> Power:.....	900 mW
H <sub>2</sub> / Air Power:.....	3000 mW
Electrode Area:.....	2.9 cm <sup>2</sup>
Permitted operating pressure:.....	0 - 20 mbar
H x W x D:.....	51 x 51 x 41 mm
Weight:.....	58 g

**Accessories:**

Gas storage tank:.....	30 mL H <sub>2</sub> & 30 mL O <sub>2</sub>
Solar module:.....	2.0V / 600 mA*
Load (fan):.....	10 mW
Load (motor of the vehicle plate):.....	150 mW

**Modular Fuel Cell:**

H <sub>2</sub> / O <sub>2</sub> mode:.....	500 mW
H <sub>2</sub> / Air mode:.....	180 mW
Electrode Area:.....	16cm <sup>2</sup>
Permitted operating pressure:.....	0 - 20 mbar
H x W x D:.....	100 x 80 x 90 mm
Weight:.....	0.2kg

\* Under standard test conditions (STC)

## Troubleshooting

The fuel cell has very little power.

Possible Cause:

- The fuel cell was stored too dry or for too long. A fuel cell with a dry polymer electrolyte membrane (PEM) loses power.

Solution:

- Continue operation. The fuel cell moistens itself during operation which slowly allows it to reach its full capacity again.

The modular fuel cell has no power.

Possible Cause:

- The modular fuel cell was installed incorrectly.

Solution:

- Disassemble the modular fuel cell again according to the instructions. Then repeat assembly step-by-step according to the instructions.

Despite hydrogen being present, the load connected to the fuel cell (e.g. the motor) is not working.

Possible Cause:

- Water has entered the fuel cell during operation (e.g. through the gas storage tanks). Drops of water in the fuel cell can block the gas feed and lead to rapid loss of power.

Solution:

- Dry the fuel cell by opening and blowing out the connections.

### CAUTION

Risk of damage from compressed air  
The use of compressed air for drying the fuel cell can cause irreparable damage to the fuel cell.  
Only blow out the fuel cell for drying without technical tools.

## Troubleshooting

With the solar module connected, no hydrogen is produced in the electrolyzer.

Possible Cause:

- The light intensity is insufficient.

Solution:

- In order to operate solar modules, either adequate direct sunlight or concentrated light from a powerful electrical light source is required. Energy-saving light bulbs, fluorescent tubes etc. are unsuitable for the operation of solar modules.

Despite correct setup, the electrolyzer or the fuel cell is not working.

Possible Cause:

- No distilled water was used. The electrolyzer and/or the fuel cell has/have sustained irreparable damage.

**Should the above-mentioned solutions not remedy the cause of error, please contact H-TEC EDUCATION.**

## Shutting down

- Continue operating the fuel cells until the consumer (e.g. the motor) stops independently. This allows some water to remain in the fuel cell, moistening the PEM. This procedure also prevents unnecessary discharge of hydrogen.
- Draining the gas storage tanks:
  - 1 . All gas has to be consumed before draining the storage tanks.



### CAUTION

Risk of injury from hydrogen ignition  
Escaping hydrogen can ignite in proximity to an ignition source. Prevent hydrogen from escaping. Completely use up all hydrogen at the end of experiments, before dismantling.

- 2 . Remove the components from the experimentation plate or vehicle plate as one unit.
- 3 . Pour water into a collecting vessel.

- Disassembly is carried out in reverse order to assembly.

Before putting the product into storage, observe the following points:

- Close the connections of fuel cells and electrolyzers with caps. This prevents the PEM from drying out. The same applies to stoppers on fuel cells.
- Remove any water droplets from the experimentation plate or vehicle plate with a soft, lint-free cloth. This prevents the formation of water stains.

## Maintenance

The components of the product do not require maintenance. The following points should be observed, though:

- Use freshly distilled water for each operation.
- After operation, remove the water from the gas storage tanks.

## Transportation and storage

With regard to transportation and storage of the product, the following points should be observed to ensure a long service life. Transport and storage only:

- in the original packaging
- dry and dust-free
- at temperatures of 4 °C to 50 °C
- protected against vibrations

## Disposal

Do not dispose of fuel cells and electrolyzers as general household waste.

 **WARNING**

Fire hazard from catalytic substances  
The catalysts for the electrodes of fuel cells and electrolyzers promote burning when they come into contact with flammable substances.  
Avoid contact with hydrogen, alcohol fumes or other organic fumes.  
Ensure correct disposal.

According to European regulations, used electric and electronic devices may no longer be disposed of as unsorted household waste. The symbol of the crossed-out wheellie bin indicates the requirement for separate disposal.

Your local waste management company can provide you with additional information about disposal options.

© H-Tec Education, 2019. No part of this guide may be reproduced in whole or in part in any manner without the express written permission of H-Tec Education. Subject to technical changes.

H-TEC EDUCATION  
1902 Pinon Dr. Unit B  
College Station, TX 77845  
USA  
Phone: +1 979-703-1925  
Fax: +1 979-314-1122  
Email: [sales@myhtec.com](mailto:sales@myhtec.com)  
Website: [www.myhtec.com](http://www.myhtec.com)